

FD-F4□/F9□

Pipe-mountable Liquid Level Detection Fiber

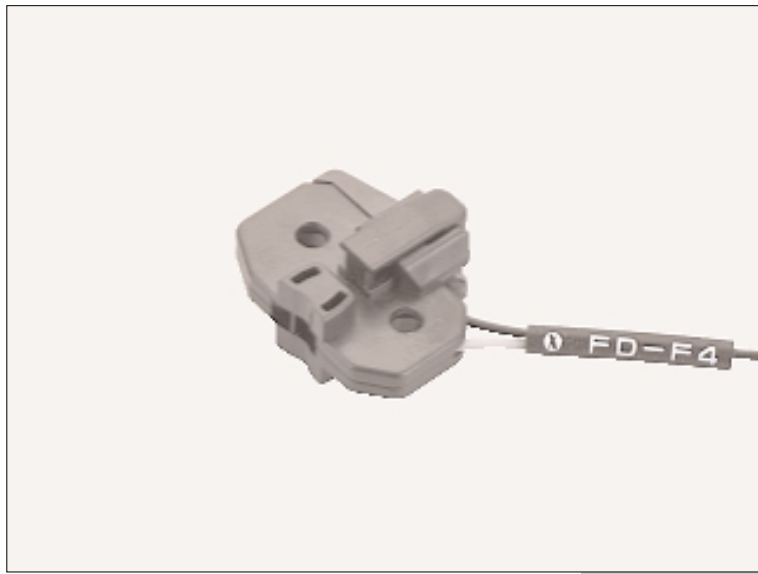

Reliable liquid level detection from outside the pipe

Widely applicable FD-F41/F91 released

FD-F41/F91 can reliably detect the liquid level inside a pipe made of, not only, PVC, but also, acrylic or glass. The range of applicable pipes has been increased by this addition to FD-F4/F9 (for 1 mm 0.039 in thick PFA pipe).

Easily mountable and adjustable

Just attach it on a pipe with the tying bands. The position can be easily changed with the release lever even after mounting, so that there is no need to cut tying bands.

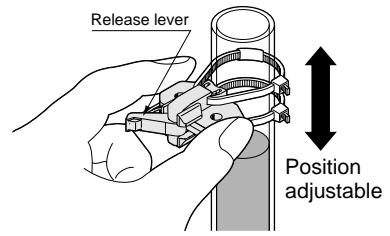

Durable up to 100 °C + 212 °F

FD-F4□/F9□ can operate under an ambient temperature of -40 to +100 °C -40 to +212 °F. Hence, even hot liquids can be safely detected.

Applicable pipe φ6 to φ26 mm φ0.236 to φ1.024 in

FD-F4□/F9□ can be mounted on a wide range of pipe diameters from φ6 to φ26 mm φ0.236 to φ1.024 in.

Compact body

The body is just 13 mm 0.512 in thick so that multi-level detection by adjacent mounting at 13 mm 0.512 in pitch is possible.

5 m 16.404 ft fiber cable length type is available

FD-F9□ is attached with a 5 m 16.404 ft long fiber cable. Hence, even if it is used in an explosive area, the amplifier can be installed outside the explosive area.

Principle of detection

When the pipe is empty, the beam is reflected from the inner surface of the pipe wall and returns to the beam-receiving part, since the difference in the refractive indexes of the pipe and air is large. When there is liquid in the pipe, the beam enters the liquid through the wall and does not return to the beam-receiving part, since the difference in the refractive indexes of the pipe and the liquid is small.

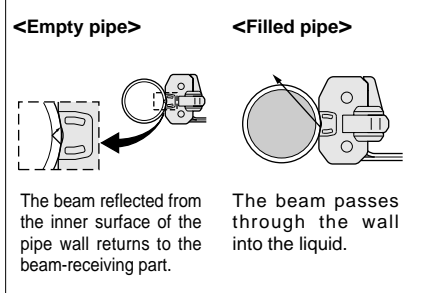

APPLICATIONS

Detecting liquid level in a tank

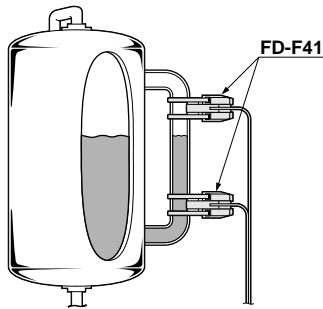

ORDER GUIDE

Fibers

Type	Appearance	Sensing object	Applicable pipe diameter (Note 2)	Fiber cable length ✂️ : Free-cut	Allowable bending radius	Model No.
Standard		Liquid (Note 1)	Outer dia φ6 to φ26 mm φ0.236 to φ1.024 in transparent pipe	✂️ 2 m 6.562 ft	 R10 mm R0.394 in	FD-F41
			(PVC, fluorine resin, polycarbonate, acrylic, glass, wall thickness 1 to 3 mm 0.039 to 0.118 in)	✂️ 5 m 16.404 ft		FD-F91
For PFA pipe, wall thickness 1 mm 0.039 in			Outer dia φ6 to φ26 mm φ0.236 to φ1.024 in transparent pipe	✂️ 2 m 6.562 ft		FD-F4
			(PFA (fluorine resin) or equivalently transparent pipe, wall thickness 1 mm 0.039 in)	✂️ 5 m 16.404 ft		FD-F9

Notes: 1) Unclear or highly viscous liquid may not be detected stably.
2) Liquid in an opaque pipe cannot be detected correctly.

Amplifiers Quick-connection cable is not supplied with the amplifier. Please order it separately.

Type	Appearance	Model No.	Emitting element	Output
Digital		FX-301	Red LED	NPN open-collector transistor
		FX-301P		PNP open-collector transistor
High-functional digital		FX-302		NPN open-collector transistor
		FX-302P		PNP open-collector transistor
High speed digital		FX-303		NPN open-collector transistor
		FX-303P		PNP open-collector transistor
Manually set		FX-311		NPN open-collector transistor
		FX-311P		PNP open-collector transistor

FD-F4□/F9□

ORDER GUIDE

Quick-connection cables Quick-connection cable is not supplied with the amplifier. Please order it separately.

Type	Model No.	Description	
Main cable	CN-73-C1	Length: 1 m 3.281 ft	0.15 mm ² 3-core cabtyre cable, with connector on one end Cable outer diameter: ϕ 3.0 mm ϕ 0.118 in.
	CN-73-C2	Length: 2 m 6.562 ft	
	CN-73-C5	Length: 5 m 16.404 ft	
Sub cable	CN-71-C1	Length: 1 m 3.281 ft	0.15 mm ² 1-core cabtyre cable, with connector on one end Cable outer diameter: ϕ 3.0 mm ϕ 0.118 in.
	CN-71-C2	Length: 2 m 6.562 ft	
	CN-71-C5	Length: 5 m 16.404 ft	

Main cable

- CN-73-C1
- CN-73-C2
- CN-73-C5

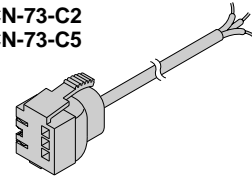

Sub cable

- CN-71-C1
- CN-71-C2
- CN-71-C5

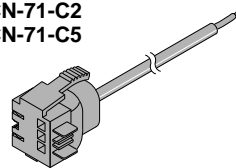

End plates End plates are not supplied with the amplifier. Please order it separately when the amplifiers are mounted in cascade.

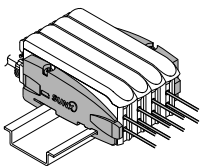
Appearance	Model No.	Description
	MS-DIN-E	When cascading multiple amplifiers, or when it moves depending on the way it is installed on a DIN rail, these end plates ensure that all amplifiers are mounted together in a secure and fully connected manner. Two pcs. per set

Accessories

• **FX-CT2**
(Fiber cutter)

• **MS-DIN-2**
(Amplifier mounting bracket)

• **FX-AT4**
(ϕ 1 mm ϕ 0.039 in fiber attachment)

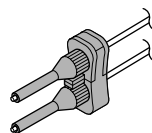
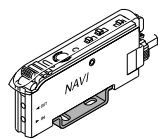
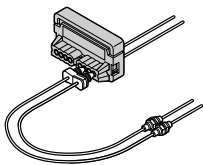

SPECIFICATIONS

Refer to [p.77/p.119/p.138/p.166](#) for amplifier specifications.

Fibers

Item	Type Model No.	Standard		For PFA pipe, wall thickness 1 mm 0.039 in	
		2 m 6.562 ft fiber cable length	5 m 16.404 ft fiber cable length	2 m 6.562 ft fiber cable length	5 m 16.404 ft fiber cable length
Applicable amplifiers		FX-301(P), FX-302(P), FX-303(P), FX-311(P)			
Sensing object		Liquid (Note 1)			
Applicable pipe diameter (Note 2)		Outer dia $\phi 6$ to $\phi 26$ mm $\phi 0.236$ to $\phi 1.024$ in transparent pipe (PVC, fluorine resin, polycarbonate, acrylic, glass, wall thickness 1 to 3 mm 0.039 to 0.118 in)		Outer dia $\phi 6$ to $\phi 26$ mm $\phi 0.236$ to $\phi 1.024$ in transparent pipe [PFA (fluorine resin) or equivalently transparent pipe, wall thickness 1 mm 0.039 in]	
Repeatability		1 mm 0.039 in or less (for water)			
Allowable bending radius		R10 mm R0.394 in or more			
Fiber cable length		2 m 6.562 ft free-cut	5 m 16.404 ft free-cut	2 m 6.562 ft free-cut	5 m 16.404 ft free-cut
Ambient temperature (Note 3)		- 40 to + 100 °C - 40 to + 212 °F (No dew condensation or icing allowed), Storage: - 40 to + 100 °C - 40 to + 212 °F			
Ambient humidity		35 to 85 % RH, Storage: 35 to 85 % RH			
Material		Fiber head: Polyetherimide, Fiber core: Acrylic, Fiber sheath: Polypropylene, Tying band: Nylon, Anti-slip tube: Silicone			
Weight		6 g approx.	11 g approx.	6 g approx.	11 g approx.
Accessories		Tying band: 4 pcs. Anti-slip tube: 2 pcs. FX-CT2 (Fiber cutter): 1 pc. FX-AT4 ($\phi 1$ mm $\phi 0.039$ in fiber attachment): 1set (Note 4)			

- Notes: 1) Unclear or highly viscous liquid may not be detected stably.
 2) Liquid in an opaque pipe cannot be detected correctly.
 3) Liquid being detected should also be kept within the rated ambient temperature range.
 4) Fiber attachments provided include **FX-AT4**, made for the **FX-301/302/303/311** series, and conventional amplifier attachments.

PRECAUTIONS FOR PROPER USE

Refer to [p.1135~](#) for general precautions and [p.90/p.121/p.141/p.168~](#) for amplifier precautions.



This product is not a safety sensor. Its use is not intended or designed to protect life and prevent body injury or property damage from dangerous parts of machinery. It is a normal object detection sensor.

Mounting

- Mount the fiber on a pipe with the attached tying bands and anti-slip tubes as shown in the figure below. Make sure that the release lever is retracted (position as shown in the figure) before mounting. Fasten two tying bands, as shown, and cut off the excess portions.

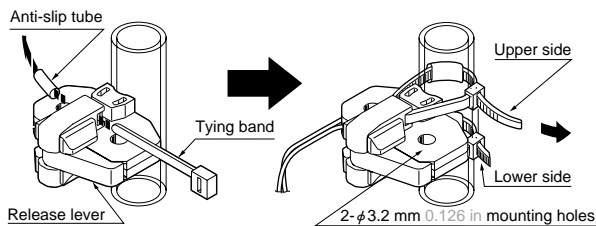

- If other tying bands are to be used, the dimension \textcircled{A} shown in the figure below should be 2.5 mm 0.098 in or less.

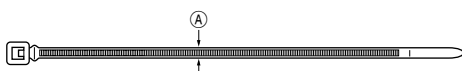

- In case of mounting using the two mounting holes, use M3 screws, plain washers, and spring washers. The tightening torque should be 0.5 N·m or less. (Please arrange the M3 screws, plain washers, and spring washers separately.)

Position adjustment

- In case of mounting on the pipe with tying bands, the fiber position can be easily adjusted.

Adjustment

- Unlock the release lever (in the direction of the arrow).
- Press the movable center holders forward to loosen the tying bands and adjust the position.
- Lock the release lever to its original place.

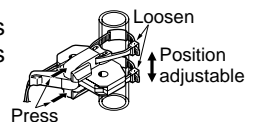

- Notes: 1) Whenever the mounting position is changed, adjust the sensitivity again.
 2) The lever mechanism must be used only to adjust the position, and not for tightening the tying bands. If tying bands are tightened while the lever is open, and then the lever is locked, the fiber may be damaged.

FD-F4□/F9□

PRECAUTIONS FOR PROPER USE Refer to p.1135~ for general precautions and p.90/p.121/p.141/p.168~ for amplifier precautions.

Fiber attachment (FX-AT4)

- When the beam-emitting and beam-receiving fibers are inserted into the fiber sensor amplifier (FX-301/302/303/311 series etc.), the enclosed fiber attachment for FX-301/302/303/311 series facilitates insertion of the fibers and reduces the possibility of incorrect fiber insertion.

Cautions

- Take care that fiber attachment for FX-301/302/303/311 series cannot be used with fiber sensor amplifiers having a pitch, between the beam-emitting and the beam-receiving fibers, other than 7 mm 0.276 in. In case of fiber sensor amplifiers having a pitch other than 7 mm 0.276 in, please use attachments for conventional amplifier.

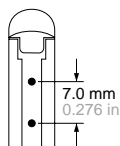

Mounting of fiber attachments

For FX-301/302/303/311 series

- Mount the holders on the gland lightly

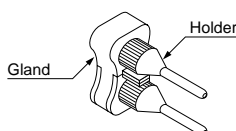

Note: If both long holders and short holders are enclosed with the fiber, use the short holders.

- Insert the fiber cables into the holders, in condition ①.
- Tighten the holders to fix the fiber cables at the desired length.
- Insert the fiber cables, in condition ③, into the holes for $\phi 1.0 \text{ mm } \phi 0.039 \text{ in}$ or $\phi 1.3 \text{ mm } \phi 0.051 \text{ in}$ fiber cables of the fiber cutter (FX-CT2) from direction shown in the figure below.

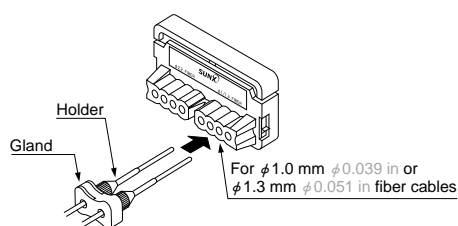

- Cut both fiber cables simultaneously. (At this time, insert the attachment to a position at which it stops. The fiber cables will be cut at a position approx. 0.5 mm 0.020 in from the holder.)
- After cutting, insert the fiber cables to the fiber sensor amplifier immediately.

For conventional amplifier

- Thread the fiber cable through the gland and holder separately, and screw the gland into the holder clockwise.



- Insert the fiber cables one by one into the holes for $\phi 1.0 \text{ mm } \phi 0.039 \text{ in}$ or $\phi 1.3 \text{ mm } \phi 0.051 \text{ in}$ fiber cable of the fiber cutter (FX-CT2) from the direction shown in the figure below.

(At this time, insert the attachment to a position at which it stops. The fiber cables will be cut at a position approx. 0.5 mm 0.020 in from the holder.)

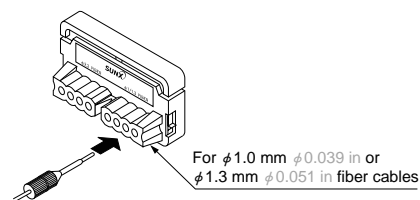

PRECAUTIONS FOR PROPER USE Refer to p.1135~ for general precautions and p.90/p.121/p.141/p.168~ for amplifier precautions.

Fiber cutter

- The fiber cables should be cut off at the ends with the fiber cutter before insertion into the amplifier.

Cutting procedure

- To cut the fiber cables, insert them from the direction shown below.

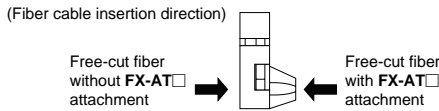

How to use fiber cutter (FX-CT2)

- ① Slide part ④ of the fiber cutter fully upward till it stops.
- ② Insert the fiber cables, mounted in the attachment, till they stop.

Take care that there are separate fiber cable insertion holes for $\phi 2.2$ mm $\phi 0.087$ in and $\phi 1.0$ mm $\phi 0.039$ in or $\phi 1.3$ mm $\phi 0.051$ in fiber cables.
- ③ Slide part ④ of the fiber cutter down to cut the fiber cables.

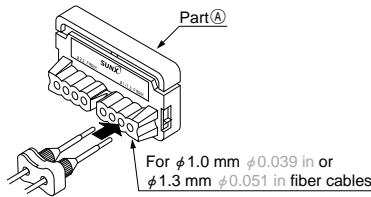

- Notes:
- 1) The fiber cables should be cut in one stroke.
 - 2) Once a fiber cable is cut off at a hole, do not use the hole again, if used, it degrades the cut surface quality and the detectability may deteriorate.
 - 3) The blade cannot be replaced. Please purchase an additional fiber cutter, if required.
 - 4) Note that the sensing range may be reduced by up to 20 % depending on the cut condition. Hence, decide the setting distance by taking sufficient margin.

Others

- Liquid in a pipe which is not transparent cannot be sensed correctly.
- Unclear or highly viscous liquid may not be sensed.
- Fit the fiber head to the pipe securely, otherwise the operation may be erroneous.
- Take care that no dew condenses on the pipe's sensing surface or the pipe's inside wall and that no bubble attaches on the pipe's inside wall, since it can affect the operation.
- If a liquid drop flows down across the sensing point or an air bubble sticks on the wall at the sensing point, the operation may be erroneous. Make sure that no bubble arises in the liquid, and that no dew or liquid drop is present on either surface of the pipe wall.
- Neither **FD-F4□** or **FD-F9□** is waterproof or chemical-resistant. Installation should be avoided at any place where it could come in direct contact with water or chemicals.
- Do not apply excessive tensile force to the fiber cable.
- Bending radius of the fiber cable must be R10 mm R0.394 in or more. If the bending radius is smaller than the specified value, the sensing performance may deteriorate.
- Do not use the fiber at places having intense vibrations, as this can cause malfunction.
- Keep the fiber head surface intact. If it is scratched or spoiled, the detectability will deteriorate.
- Do not expose the fiber cable to any organic solvents.
- Ensure that any strong extraneous light is not incident on the receiving face of the fiber head.
- Take care that the sensor is not directly exposed to fluorescent light from a rapid-starter lamp or a high frequency lighting device as it may affect the sensing performance.

FD-F4□/F9□

PRECAUTIONS FOR PROPER USE

Refer to p.1135~ for general precautions and p.90/p.121/p.141/p.168~ for amplifier precautions.









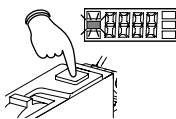

Teaching

When using in combination with the FX-301(P), the FX-302(P) and the FX-303(P)

- The threshold values can be set by either 2-level teaching or limit teaching, when the MODE indicator / TEACH (yellow) lights up.

<In case of 2-level teaching>









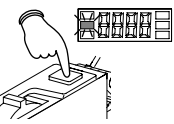

- This is the method of setting the threshold value by teaching two levels, corresponding to the liquid present and liquid absent conditions. Normally, setting is done by this method.

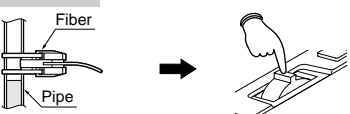
Step	Description	Display
①	Press MODE key to light up MODE indicator / TEACH (yellow). 	
②	Press jog switch in the liquid absent condition. If the teaching is accepted, the read incident light intensity blinks in the digital display. Liquid absent 	
③	MODE indicator / TEACH (yellow) blinks. Press jog switch in the liquid present condition. Liquid present 	
④	If the teaching is accepted, the read incident light intensity blinks in the digital display and the threshold value is set at the mid-value between the incident light intensities in the liquid present and the liquid absent conditions. After this, the judgment on the stability of sensing is displayed. • In case stable sensing is possible: 'Good' is displayed. Stability indicator (green) blinks. • In case stable sensing is not possible: 'Err d' is displayed. Stability indicator (green) is off.	 
⑤	The threshold value is displayed.	
⑥	' ' blinks in the digital display.	
⑦	The incident light intensity appears in the digital display and the setting is complete.	

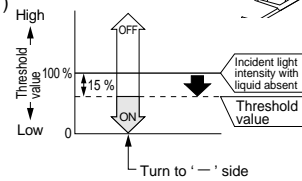
Note: Do not move or bend the fiber cable after the sensitivity setting. Detection may become unstable.

<In case of limit teaching>

- This is the method of setting the threshold value by teaching only the liquid absent condition (stable incident light condition).

Step	Description	Display
①	Press MODE key to light up MODE indicator / TEACH (yellow). 	
②	Press jog switch in the liquid absent condition. If the teaching is accepted, the read incident light intensity blinks in the display. Liquid absent 	
③	MODE indicator / TEACH (yellow) blinks. Turn jog switch to the ' - ' side.	
④	If jog switch is turned to the ' - ' side, ' . ' scrolls (twice) the display from left to right, and the threshold level is shifted to a value approx. 15 % lower (higher sensitivity) than that set at ②. (Note 1) 	
⑤	After this, the judgment on whether the setting shift amount can be shifted or not is displayed. • In case shifting is possible: 'Good' is displayed. • In case shifting is not possible: 'Err d' is displayed.	 
⑥	The threshold value is displayed.	
⑦	' ' blinks in the digital display.	
⑧	The incident light intensity appears in the digital display and the setting is complete.	

Notes: 1) The approx. 15 % amount of shift is the initial value. The amount of shift can be changed in the PRO mode from approx. 5 to 80 % (5 % step). Refer to 'Fiber Sensor Guide Book' or 'SUNX fiber sensor homepage' (<http://www.fiber-sensor.com>) for details of the setting method.

2) Do not move or bend the fiber cable after the sensitivity setting. Detection may become unstable.

PRECAUTIONS FOR PROPER USE Refer to p.1135~ for general precautions and p.90/p.121/p.141/p.168~ for amplifier precautions.

Sensitivity adjustment

When combining with the FX-311(P)

- Adjust the sensitivity, observing the operation indicator (orange). However, since the condition for lighting up of the indicator depends on the combination of the sensing condition and selected operation for L/D-ON, verify it from the table on the right.
- The sensitivity adjuster is a 12-turn potentiometer. The maximum sensitivity is obtained by turning it fully clockwise.
- The pointer shows the present sensitivity level.

Sensing condition	MODE		Operation indicator
	L-ON (ON when liquid absent)	D-ON (ON when liquid present)	
Light (liquid absent)	L-ON (ON when liquid absent)	D-ON (ON when liquid present)	☀
	D-ON (ON when liquid present)	L-ON (ON when liquid absent)	●
Dark (liquid present)	L-ON (ON when liquid absent)	D-ON (ON when liquid present)	●
	D-ON (ON when liquid present)	L-ON (ON when liquid absent)	☀

☀ : Lights up ● : Lights off

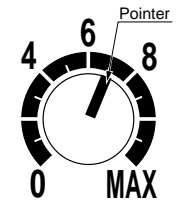

<Sensitivity indicator>

<Assist function>

- This product incorporates an 'assist function', which helps to easily search the optimum sensitivity position by blinking of the pointer. In order to make 'assist function' effective, switch the operation selection switch in the order L-ON (Light-ON) → D-ON (Dark-ON) → L-ON (Light-ON).

Notes: 1) 'Assist function' turns off automatically once the sensitivity adjustment has been completed.
 2) In case 'assist function' is not to be used, set the operation selection switch to D-ON (Dark-ON) and wait for 2 sec., or more, to make 'assist function' ineffective.

Step	Sensing method	Operation	Sensitivity indicator
①		★Make sure that the operation selection switch is set to L-ON (Light-ON). In case 'assist function' is to be used, switch the operation selection switch in the order of L-ON (Light-ON) → D-ON (Dark-ON) → L-ON (Light-ON).	Turn the sensitivity adjuster fully counterclockwise. (Minimum sensitivity)
②	Liquid absent 	In the liquid absent condition, slowly turn the adjuster clockwise and find the point (A) where the sensor is switched ON. The pointer blinks once at the point (A). (Note 1)	
③	Liquid present 	In the liquid present condition, slowly turn the adjuster further clockwise until the sensor goes into the ON state again. Once it is switched on, turn the adjuster counterclockwise a little and find the point (B) where it is switched OFF. The pointer blinks twice at the point (B). (Note 2) (If the sensor does not go into the ON state, MAX is the point (B).)	
④		Turn the adjuster towards the point (A) from the point (B) slowly. The pointer starts blinking when it approaches the optimum sensitivity point and blinks faster at the optimum sensitivity point for 3 sec. This point is the optimum sensitivity point. (Note 2)	
⑤		Select either L-ON (Light-ON) or D-ON (Dark-ON) according to your application.	

- Notes: 1) When 'assist function' is not used, the pointer does not blink.
 2) When 'assist function' is not used, the middle point of (A) and (B) is regarded as the optimum sensitivity point.
 3) In order to protect the mechanism, the sensitivity adjuster idles when over turned, which may result in a backlash of 1 to 2 divisions.
 4) Depending upon the sensing conditions, stable sensing may be possible at a position which is slightly shifted from the optimum sensitivity point.
 5) Do not move or bend the fiber cable after the sensitivity adjustment. Detection may become unstable.

DIMENSIONS (Unit: mm in)

The CAD data in the dimensions can be downloaded from the SUNX website: <http://www.sunx.co.jp/>
 Refer to p.102/p.127/p.143/p.170 for amplifier dimensions.

FD-F41 FD-F91
FD-F4 FD-F9

Free-cut With FX-AT4

